



(AN ISO CERTIFIED 9001:2015 COMPANY)

PRODUCT MANUAL OF LOAD MOMENT INDICATOR

Introduction of Load Moment Indicator

This Load Moment Indicator (LMI) Fitted to a EOT & Gantry designed to alert the operator if the lift is exceeding the Safe operating range of the machinery. In some cases, the device will physically lock the machinery in circumstances it determines to be unsafe. LMI systems are usually composed of a microprocessor connected to various sensors on the crane if self. The LMI measures the load weight and compares this with the manufacturer's specification to determine if the lift is safe. Load Moment Indicator means a system which the Equipment operator by sensing (Directly OR Indirectly) The overturning Moment on the Equipment, Load multiplied by radius.

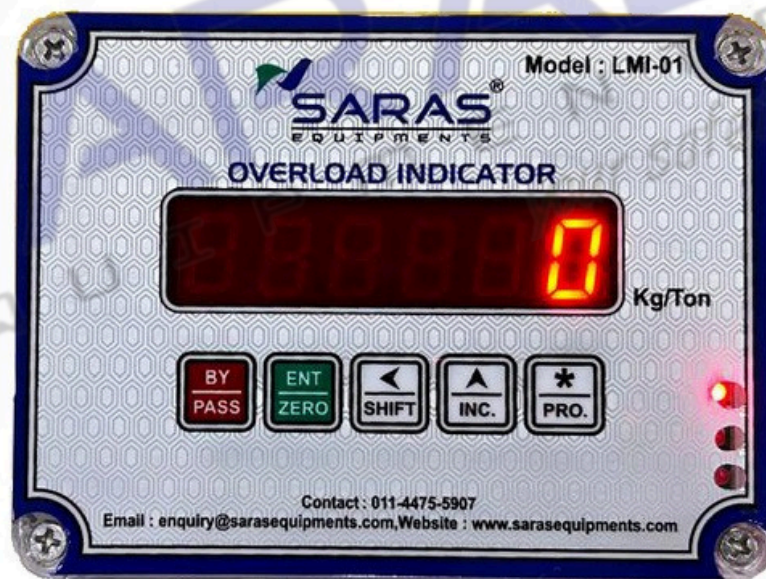

BLOCK DIAGRAM-1

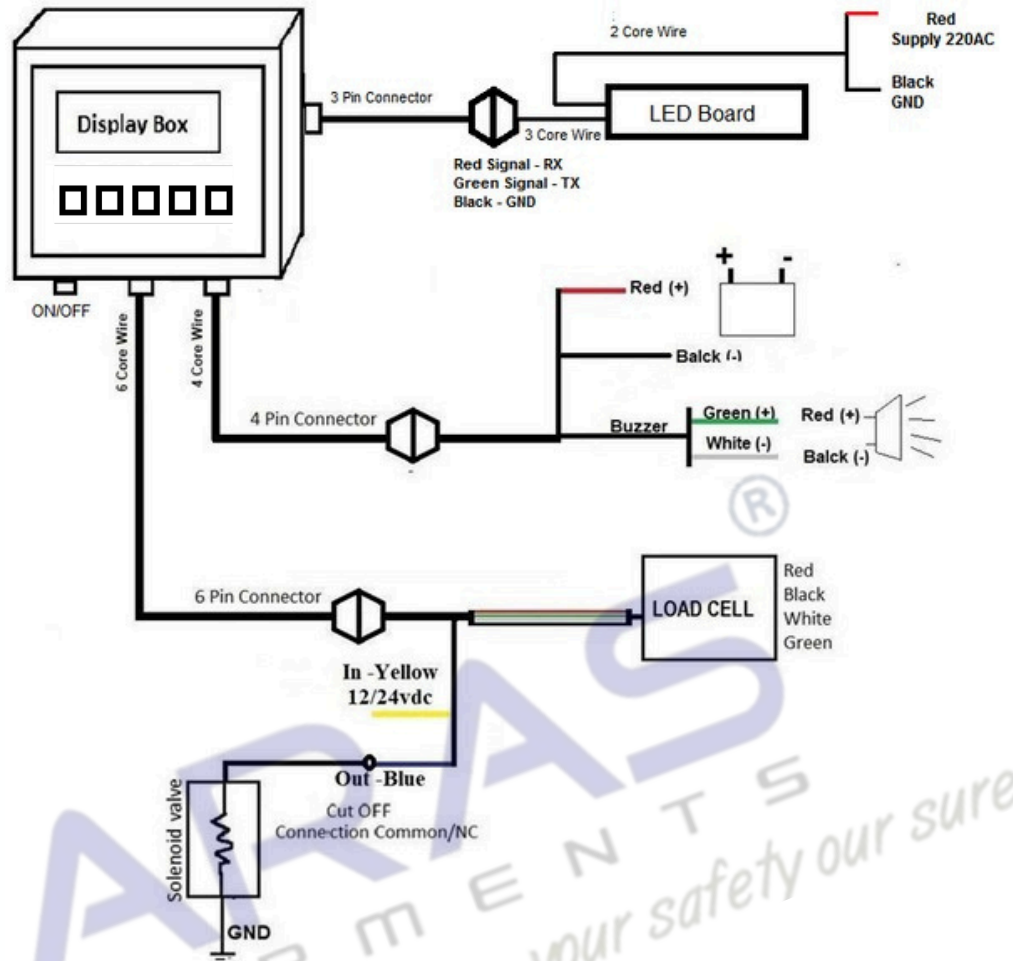

BLOCK DIAGRAM-2

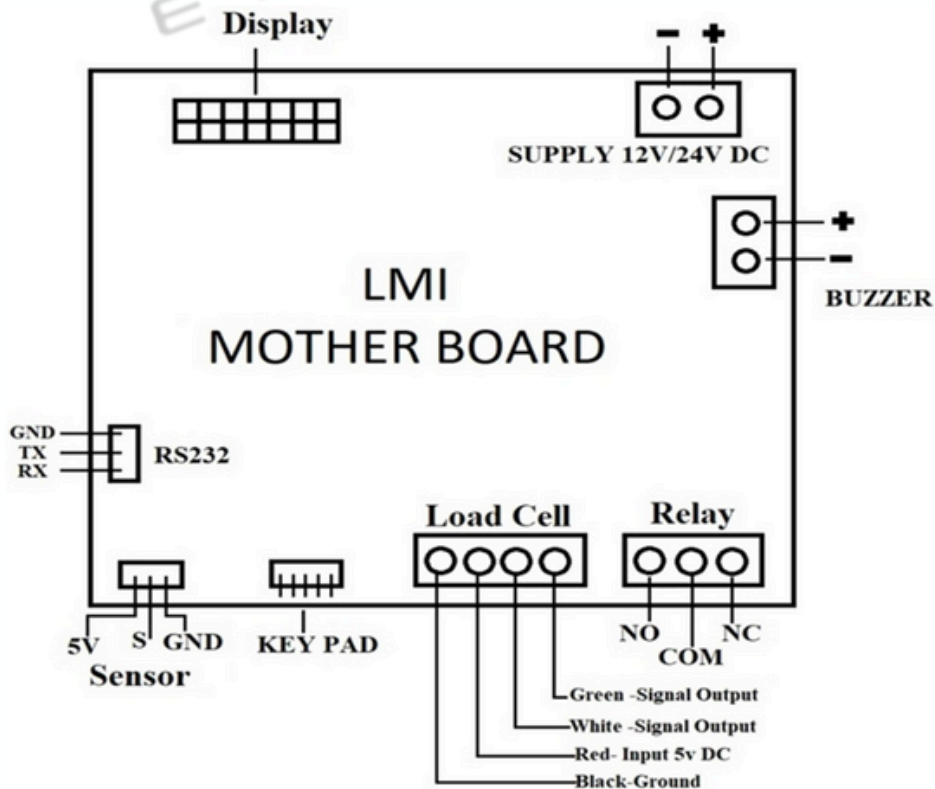

LOAD CELL

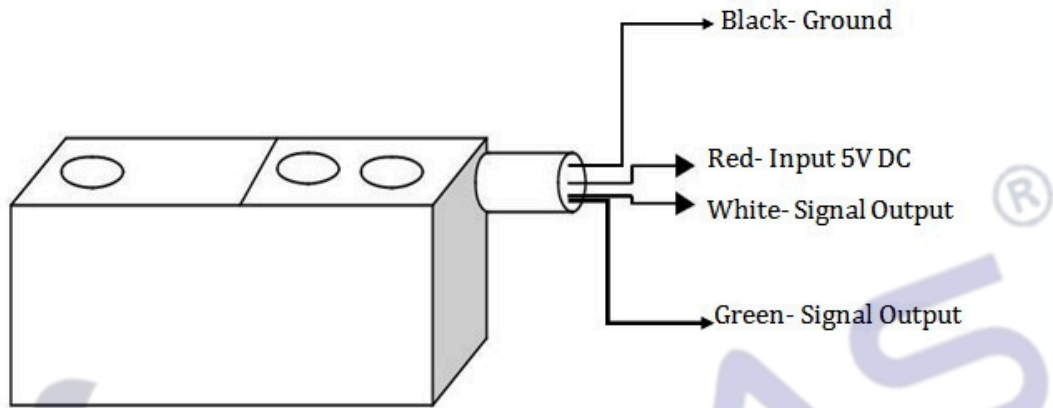

LED BOARD

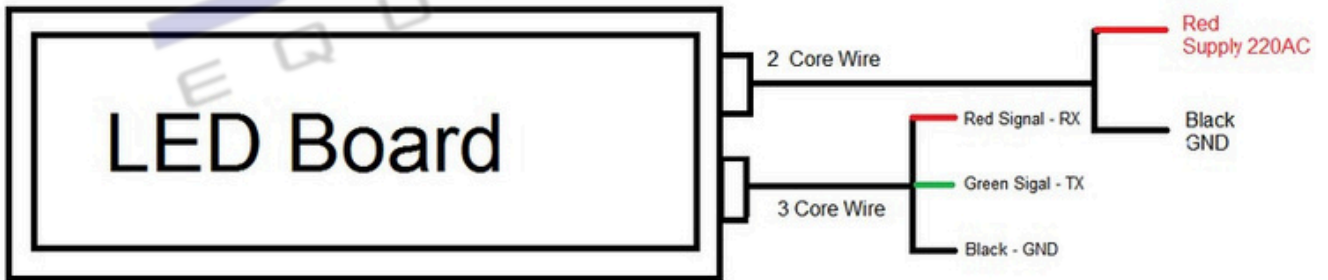

USER MANUAL

1. ON/OFF use for LMI

WIRE Connection Information

2. WIRE 6 CORE Details

Red	—————→	+VE (12V) FOR (LOAD CELL)
Black	—————→	-VE (GROUND) FOR (LOAD CELL)
White	—————→	- FOR SIGNAL (LOAD CELL)
Green	—————→	+VE FOR SIGNAL (LOAD CELL)
Yellow	—————→	COMMON (CUT OFF)
Blue	—————→	NC (CUT OFF)

3. WIRE 4 CORE DETAILS

Red	—————→	+VE (12V) FOR MAIN SUPPLY
Black	—————→	-VE (GROUND) FOR MAIN SUPPLY
Yellow	—————→	- FOR BUZZER (ALARM)
Green	—————→	+VE FOR BUZZER (ALARM)

4. WIRE 3 CORE LED DETAILS

Red	—————→	Signal (RX)
Green	—————→	Signal (TX)
Black	—————→	GND

KEY INFORMATION

1. ENTER
2. SHIFT
3. INCREASE
4. PROGRAM
5. BYPASS

- ENTER** → Enter Program switch using for Calibration and secondly to set TARE (ZERO) weight.
- SHIFT** → SHIFT this key use is SHIFT the digit in Calibration reading.
- INCREASE** → Increase this key use is increase/decrease the digit in calibration readings.
- PROGRAM** → This key is using to set or adjust various parameters and feed the data.
- BYPASS** → By integrating a cut-off function into the standard system, the Load Moment Indicator will now selectively bypass only the unsafe crane movements, rather than freezing all motions. This enables the operator to continue controlling only those movements that will safely bring the crane to a secure condition.

Load Calibration Procedure:

Follow these steps to calibrate the load:

1. Connect Load Cells: Ensure all load cells and Cut off connections are Connected.
2. Place/Lift a known weight on the platform/hook.
3. Confirm that the displayed load increases with the lifted weight.
4. The weight and make zero to the load by pressing the ENT button.
5. Place/Lift a known weight on the platform/hook for calibration.
6. Press the INC (▲) and PRO (*) buttons simultaneously until "ENTER" is displayed. Then press the ENT button.
7. If you want to keep 10Ton, then put the actual weight of 000100 and press ENT. (Use the SHIFT (◀) and INC (▲) buttons to set the load).
8. By following these steps precisely, you can successfully calibrate the load for accurate measurements.

TECHNICAL SPECIFICATION

POWER SUPPLY	(12V/24V) DC
RELAY WORKING VOLTAGE	110-240V AC , 12-24V DC
ACCURACY	+/- 5 % OR BETTER
STORAGE TEMPERATURE	20° TO 80° C
OPERATING TEMPERATURE	0 – 60° C
ENVIRONMENTAL PROTECTION	IP65
RELAY CUT OFF	YES
OVER LOAD BUZZER	YES
LIFTING CAPACITY UP TO	10 KG TO 100 TON



Saras Equipments Private Limited

Add: Building Number, 12, Naresh Park, Nangloi, New Delhi 110041 Mail us at: sarasequipments@gmail.com

Visit us at: www.sarasequipments.com

WE CARE ABOUT EVERY CUSTOMER